



# SPECIFICATION

## 产品规格书

Customer(客户): \_\_\_\_\_  
Part No.(型号): 9.HCF35-451  
Description(描述): 3535 730nm Red LED  
Date(日期): 2023.04.14

Customer Approved (客户审核)		Approved (确认)	
Xuyu Approved (旭宇审核)		Approved (确认)	Issued (制定)
<input checked="" type="checkbox"/> Sample (样品) <input type="checkbox"/> Mass Product (量产供货)			



### XUYU OPTOELECTRONICS (SHENZHEN)



### ◆ Features 特性:

- \* Small package with high efficiency 体积小，光效高
- \* Low voltage operation, Instant light 电压低，发光响应快
- \* Long operation life 工作寿命长
- \* Lead free product 不含铅，环保
- \* RoHS compliant 通过 RoHS 认证

### ◆ Applications 产品应用:

- \* Horticulture Lighting 植物照明

## ◆ Package Dimensions 产品外观尺寸

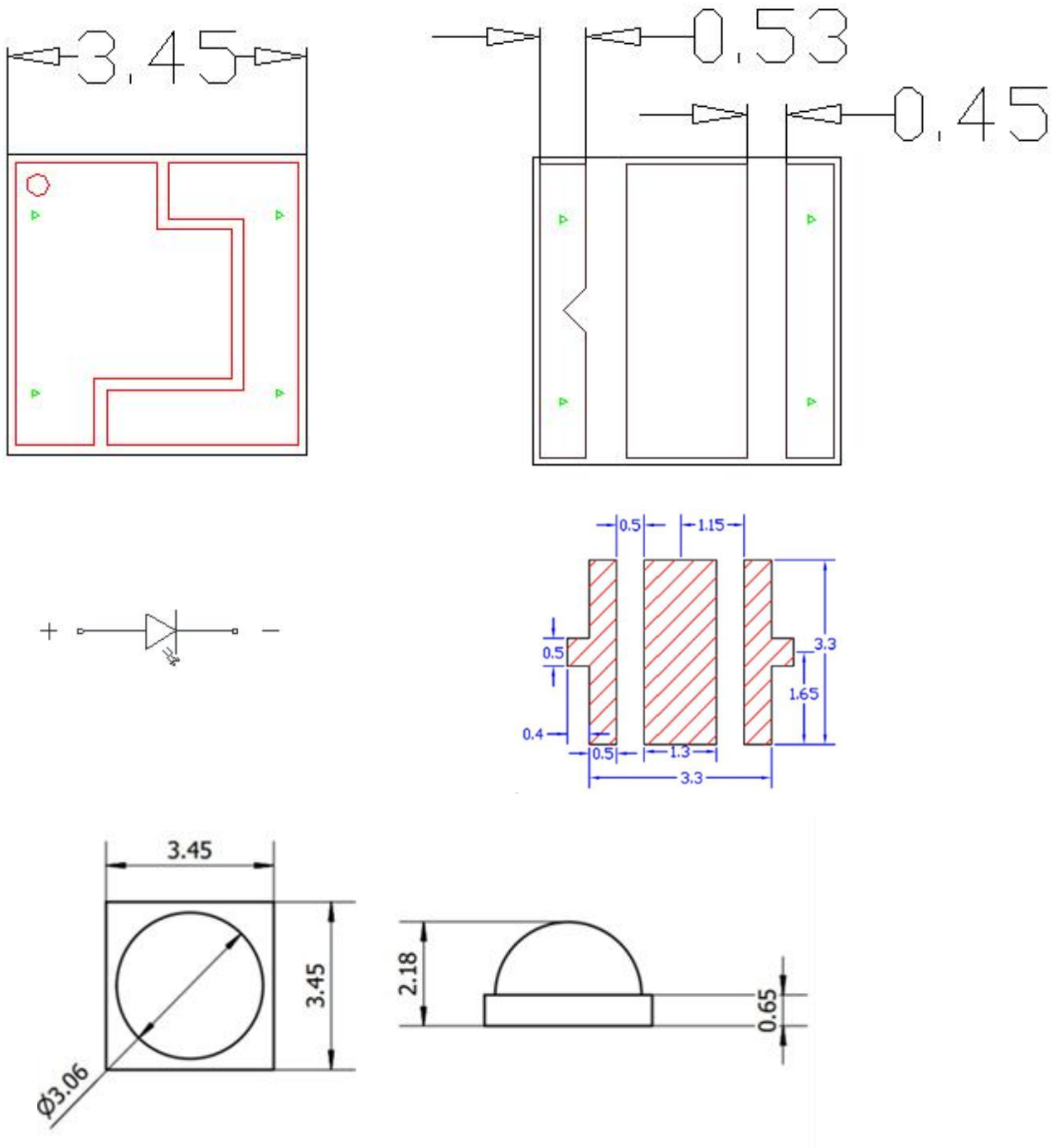

### Notes:

1. All dimensions are in mm 所有尺寸单位为毫米。
2. Tolerance is  $\pm 0.2$  mm unless otherwise noted. 非特殊标注，公差为 $\pm 0.2$ 毫米。



◆ Product coding rules 产品编码规则

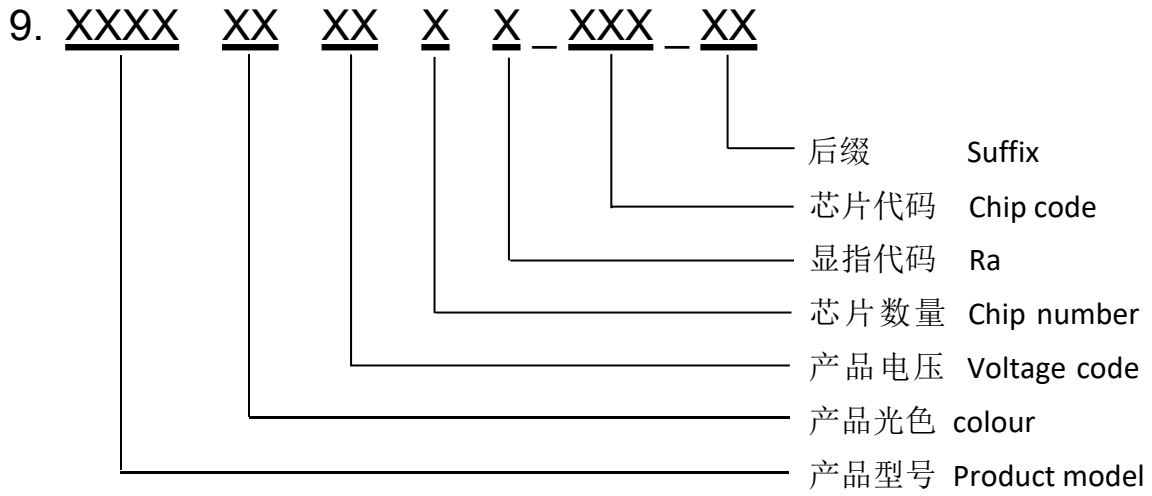



◆ Electrical-Optical Characteristics (Ta=25°C) 光电特性

Parameter 参数	Test Condition 测试条件	Symbol 符号	Min 最小值	Typ 典型值	Max 最大值	Unit 单位
Forward Voltage 正向电压	$I_F=350\text{mA}$	$V_F$	1.8	---	2.4	V
Reverse Current 反向电流	$V_R=-5\text{V}$	$I_R$	---	---	10	$\mu\text{A}$
View Angle 发光角度	$I_F=350\text{mA}$	$2\theta_{1/2}$	---	120	---	deg.
Centroid Wavelength 中心波长	$I_F=350\text{mA}$	$\lambda_c$	720	730	740	nm
Radiation Flux 辐射通量	$I_F=350\text{mA}$	$\Phi$	350	--	450	mW

**Note:** the test tolerance 测试公差

$V_F : \pm 1\%$

$\lambda_d : \pm 5\%$

$\Phi : \pm 10\%$

◆ **Absolute Ratings (Ta=25°C) 最大值**

Parameter 参数	Symbol 符号	Rating 等级	Unit 单位
Power Dissipation 额定功率	P <sub>D</sub>	3	W
Forward Current 正向电流	I <sub>F</sub>	1000	mA
Peak Forward Current 脉冲电流	I <sub>FP</sub>	1500	mA
Operation Temperature Range 操作温度范围	T <sub>opr</sub>	-40 To +105	°C
Storage Temperature Range 储存温度范围	T <sub>stg</sub>	-40 To +105	°C
Junction Temperature 结温	T <sub>j</sub>	125	°C
ESD Sensitivity (HBM) 抗静电能力(人体模式)	--	2000	V
Soldering Temperature 回流温度	T <sub>slid</sub>	260°C <10s	

**Note:** Frequency 10KHz, duty ratio ≤10%    频率 10KHz ， 占空比 ≤10%

## ◆ Typical Electrical/Optical Characteristic Curves 典型光电特性曲线

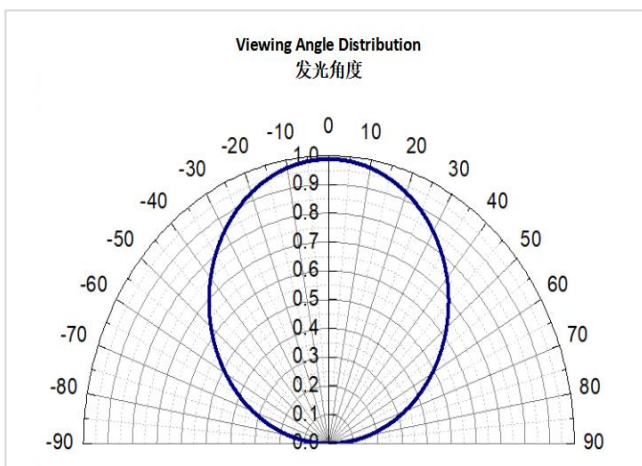
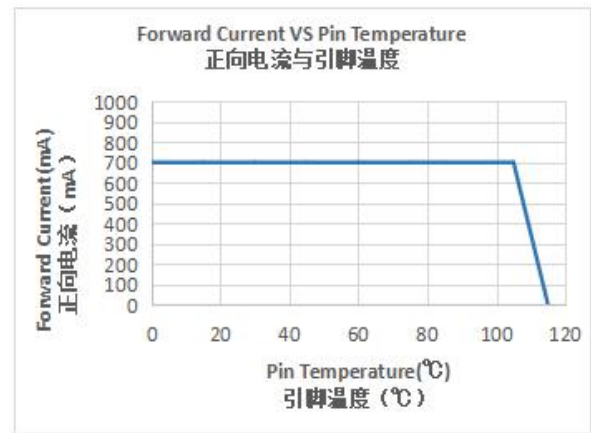
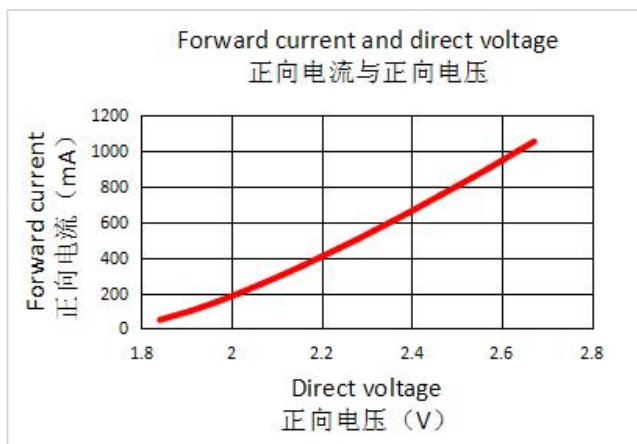
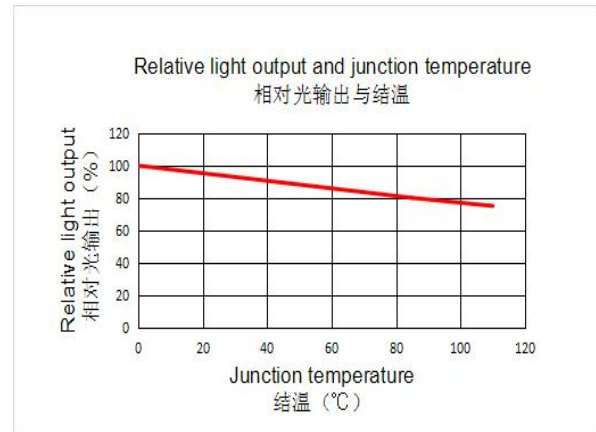
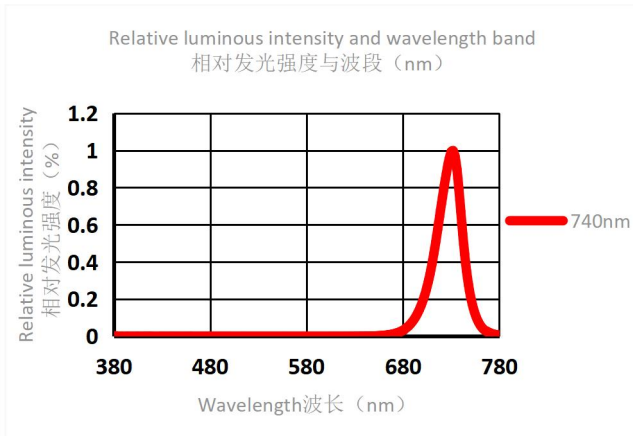

### Notes:

1. Related to the temperature test based on the right current. 与温度相关测试基于额定电流。
2. All measurements were made under the standardized environment of XUYU. 所有测试都是基于旭宇光电 (深圳) 股份有限公司现有的标准测试平台。

## ◆ Reliability 信赖性测试项目及测试条件

### 1. Test Items And Results 测试项目及结果

Item 项目	Test conditions 测试条件	Note 测试频率	Number of Damaged 损坏数量
Reflow 回流焊	Temp:260°C max T=10 sec	2 time	0/22
Thermal Shock 冷热冲击	-40~100°C 30min, 10s, 30min The 300 round	100cycles	0/22
High Temperature High Humidity Storage 高温高湿储存	Ta=85°C, RH=85%	300hrs	0/22
Steady State Operating life 常温通电	Ta=25°C, I <sub>F</sub> =350mA	1000hrs	0/22
Steady State Operating life of High Humidity Heat 高温高湿通电	Ta=60°C RH=85%, I <sub>F</sub> =350mA	1000hrs	0/22
High Temperature Storage 高温储存	Ta=100°C	1000Hrs	0/22
Low Temperature Storage 低温储存	Ta=-40°C	1000Hrs	0/22

### 2. Criteria for Judging The Damage 失效判定标准

Item 项目	Symbol 符号	Test Conditions 测试条件	Criteria for Judgment 判定标准	
			Min.最小	Max.最大
Forward Voltage 正向电压	V <sub>F</sub>	I <sub>F</sub> =350mA	---	Initial Data 初始数据 × 1.1
Luminous Intensity 发光强度	I <sub>V</sub>	I <sub>F</sub> =350mA	Initial Data 初始数据 × 0.7	---
Reverse Current 反向电流	I <sub>R</sub>	V <sub>R</sub> =5V	---	> 10uA



◆ Packaging Specifications 包装规格

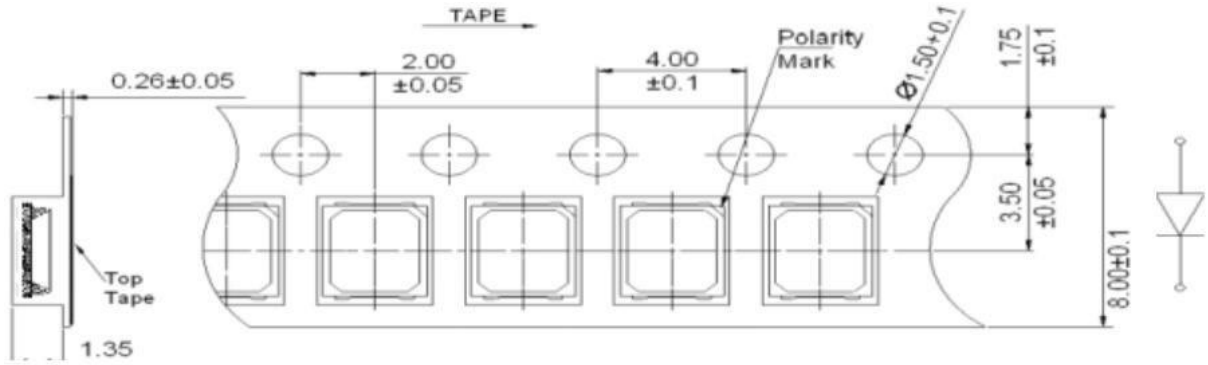

Dimensions of Reel 卷盘规格

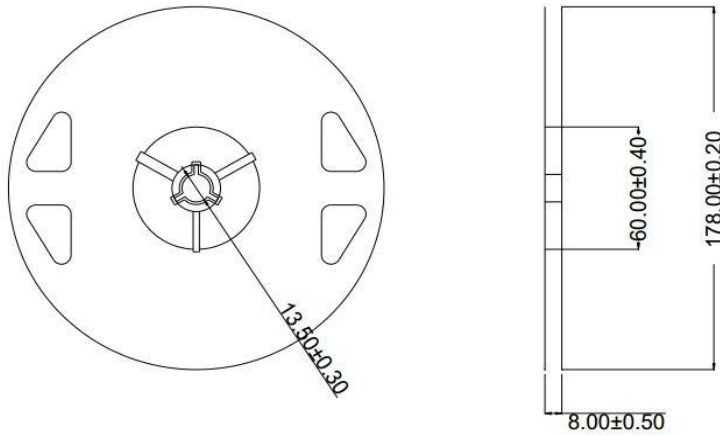

Packaging specifications 包装规格

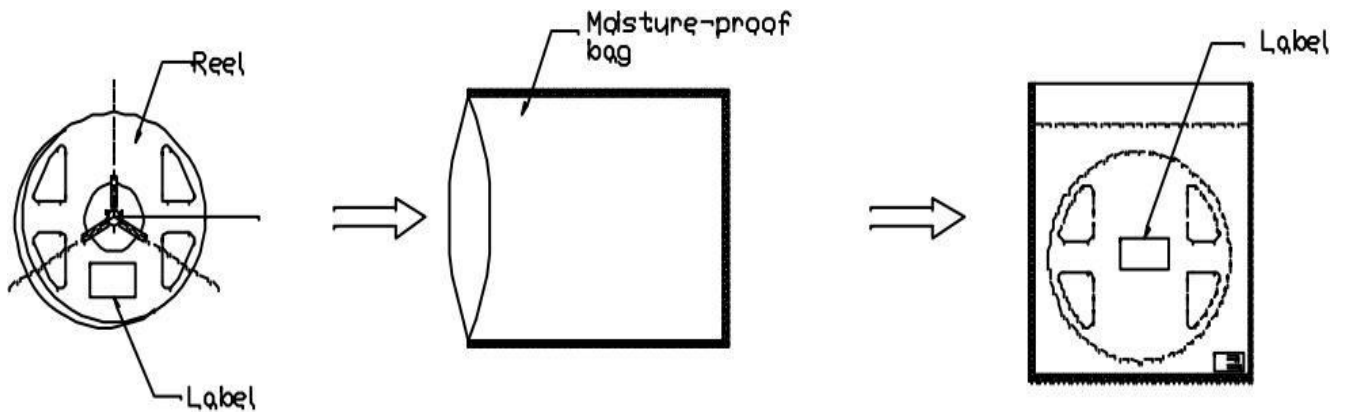

**Label(标签):**

Part NO: 产品型号 Product model

LOT NO: 指令单号 Instruction number

IV/PO: 光通量/功率 Luminous flux /Power

VF/IF: 电压/电流 Voltage /Electric current

CCT/XY: 色温/色区 Color temperature / Color Coordinates

Ra/SD/PPE: 显色指数/色容差/光合光量子效率 Color Rendering index/Color tolerance /PPE

Q' ty: 数量 Quantity

Date: 日期 Date

Code: 产品代码 Product code



## ◆ SMT Reflow Soldering Instructions SMT 回流焊说明

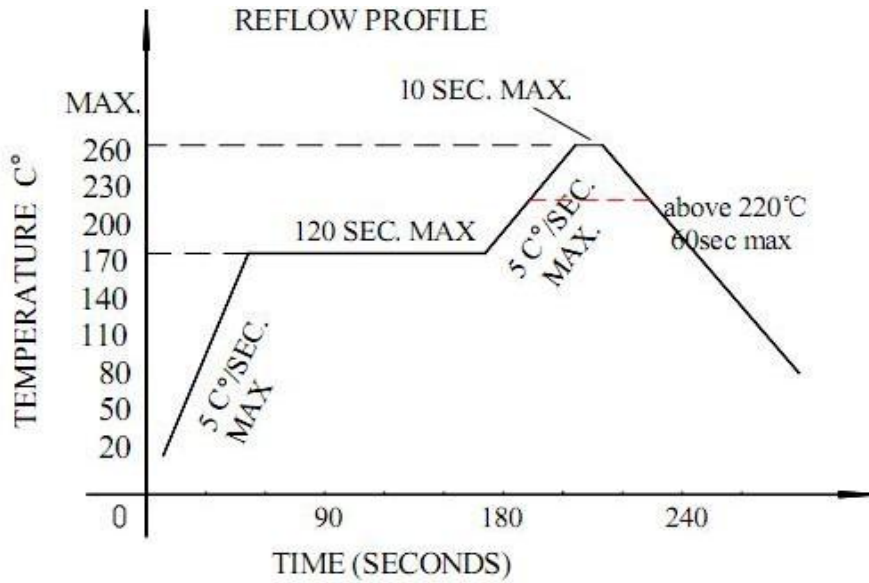

1. Reflow soldering should not be done more than two times  
回流焊不可以做两次以上。
2. When soldering, do not put stress on the LEDs during heating  
当焊接时，材料受热，不可以用力按压胶体表面。

## ◆ CAUTIONS 注意事项

1. The encapsulated material of the LEDs is silicone ,so the surface of LED colloid is softer, forcing the colloid surface hard will affect the reliability of LED.

1、LED 封装为硅胶，故 LED 胶体表面较软，用力按压胶体表面会影响 LED 可靠性。

2. Material confirmation. Whether the LED Bin specifications of the material are consistent , such as whether  $V_F$ , XY, brightness and so on belong to the same specification, the same specification should be used together, if not the same specification LED is applied to the same object, it should be evaluated first, (if different  $V_F$  or XY cast together may produce difference in brightness or color).

2、物料确认。投料的 LED Bin 规格是否一致，如  $V_F$ 、XY、亮度等是否属同一规格，同一规格的应在一起使用，若不是同一规格的 LED 应用在同一物件上，应先评估其适用性，（若不同  $V_F$  或 XY 投在一起可能会发生亮度上或颜色上的差异）。

3. Packaging and storage 。

3.1 Before opening the package, please check the packaging bag for air leakage. If there is any air leakage, please return it to our company to re-bake the dehumidifying package before use.

3.2 Open the precautions after packing. LED is a surface mount. When the LED is welded, the internal separation of LED may occur. The luminescence efficiency is affected and the luminance decreases or the color variation. The following are the matters to be paid attention to:

A, After opening the package, welding should be completed as soon as possible (within 12 hours).

B, The remaining materials are sealed or placed in an environment of 5~40 C and no more than 30% humidity.

C, If the open package is more than 24 hours (< 168 hours) or the humidity card is changed from blue to pink, LED needs to be dehumidifying again (65 degrees centigrade for more than /24 hours). If the package is opened for more than 168 hours, it is necessary to dismantle the tape and remove the moisture at 150°C /2h.

3.3, LED electrode and bracket are made of silver plated copper alloy. The silver layer on the surface is easy to be affected by corrosive gases. Please avoid contacting with corrosive environment to cause LED discoloration, so as to avoid the poor weldability of LED and influence the photoelectric performance. Avoid sudden changes in temperature and humidity of the environment, especially under high humidity environment, easy to produce water vapor condensation.

3、包装储存。

3.1 开包装前避免湿气进入 LED 内部，建议 SMD 系列 LED 存放在内置干燥剂的干燥柜中，储存环境为温度 5-30°C，湿度不超过 50%，若存储时间超过 3 个月，LED 需要重新除潮（65°C/24 小时以上）。

3.2 打开包装后的预防措施。LED 是表面贴装件，当 LED 进行焊接时，可能会发生 LED 内部分离，其发光效率受到影响而导致亮度下降或发光颜色变异。以下是需注意的事项：

A、在开包装之前，请先检查包装袋有无漏气，如果有漏气现象，请退回我司重新烘烤除湿包装后再使用。



B、余料请密封或放置在 5~40℃、湿度不超过 30%的环境中。

C、如果开包装超过 24 小时（<168 小时）或湿度卡由蓝色变为粉红色，LED 需要重新除潮（65℃/24 小时以上），如果开包装超过 168 小时，需要拆开卷带，除潮 150℃/2h。

3.3 LED 电极和支架是由镀银的铜合金组成，外表银层易受到腐蚀性的气体影响，请避免接触腐蚀的环境造成 LED 变色，以免产生 LED 的焊接性变差或者影响光电性能。请避免环境温湿度的骤变，尤其是高湿环境下易产生水汽凝结。

4. Electrostatic protection. LED is a chip sensitive electronic component. Various measures should be taken to avoid static electricity, such as wearing an electrostatic bracelet or anti-static gloves during use. All devices, equipment and instruments should be well grounded.

4、静电防护。LED 是晶片敏感电子元器件，应采取各种措施避免静电，诸如在使用过程中戴静电手环或防静电手套。所有的装置、设备仪器应良好接地。

5, The bracket of this product is made of PCT, which is easy to break when bent. It is not suitable for lamps such as flexible light panels.

5、本产品支架为 PCT 材质，折弯易断裂，不适用于软灯板之类的灯具。